



Access control by
IXARO paging system



The IXARO paging system allows to control the access of vehicles to areas (warehouses) secured by barriers (a boom that is lifted by a motor). The truck driver is authorized by hand out of a pager to open the barrier by a remote control button on the pager.

1. Intended purpose and concept

After the waiting driver got a message ❶ to pick up his cargo he drives to the barrier. By pressing the button at the right side of the pager a open command to open the barrier is sent ❷ from the pager to the receiver at the barrier control electronics.

The enabling technology is the IXARO TwoWay-pager AK500 which is also a transmitter. This offers the option to protocol barrier openings if the message center is equipped with a receiver. The receiver at the center is not necessary however to remotely open the barrier.

Figure 1 provides an overview of the system.

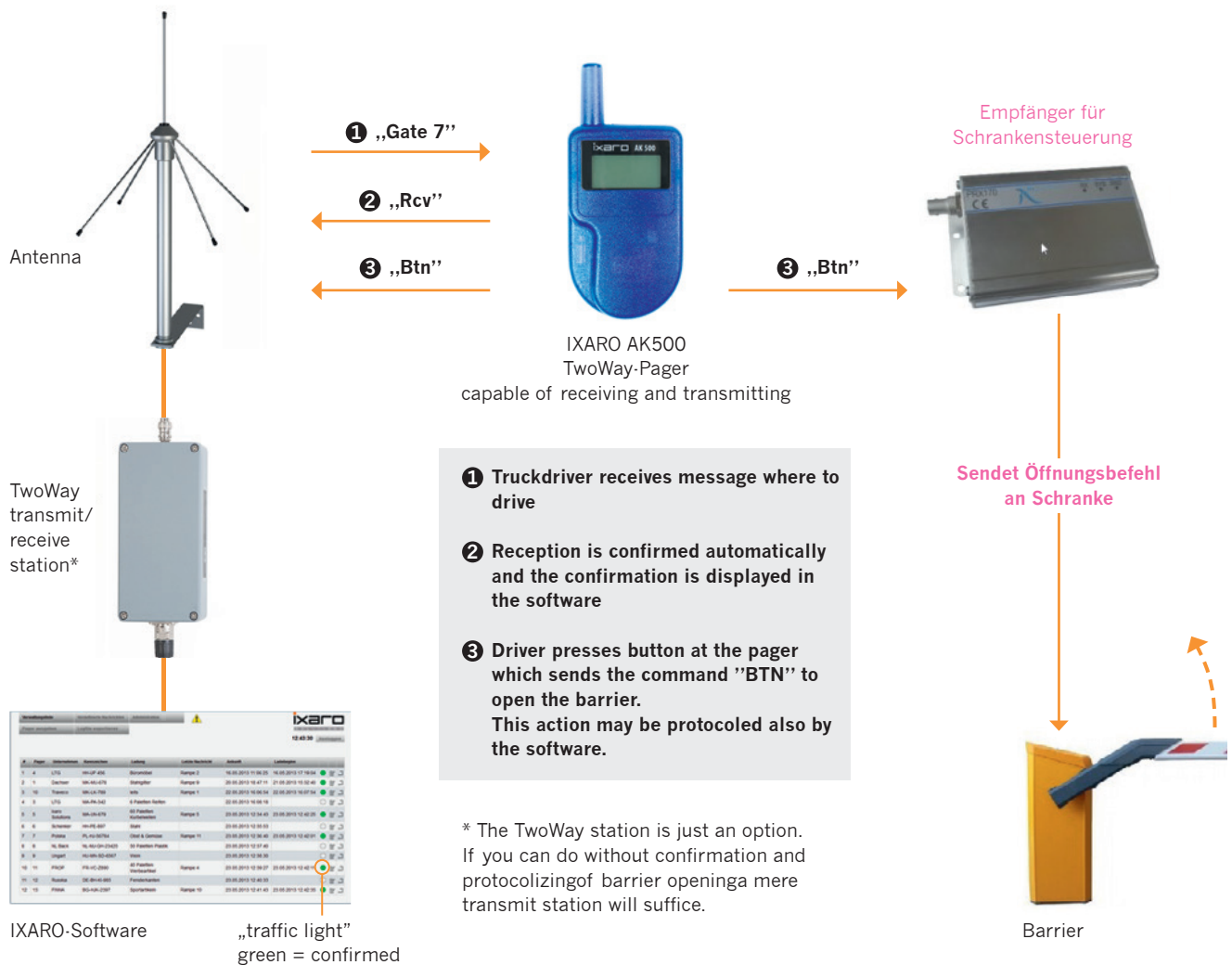


Fig. 1:

Overview of an IXARO paging system with barrier control. The center transmits messages at frequency 433.5 MHz to the pager. At the push of a button the pager sends at 434.7 MHz the command to open the barrier to the receiver connected to the barrier control electronics.

The system works license exempt and free of royalty in the 433 MHz SRD band

2. Installation

2.1 Installation of the receiver

To install the system a receiver ST-18 (Fig. 2, 3) and an antenna (Fig.4) have to be mounted in the casing of the barriers drive. The casing usually houses the motor of the boom and the control electronics. The control electronics has inputs for switches which open the barrier when programmed properly. The receiver has an corresponding output which closes a relay contact for 0.3 s when the open command is received from the pager (time can be adjusted when needed). The receiver is delivered with a 12V power supply.

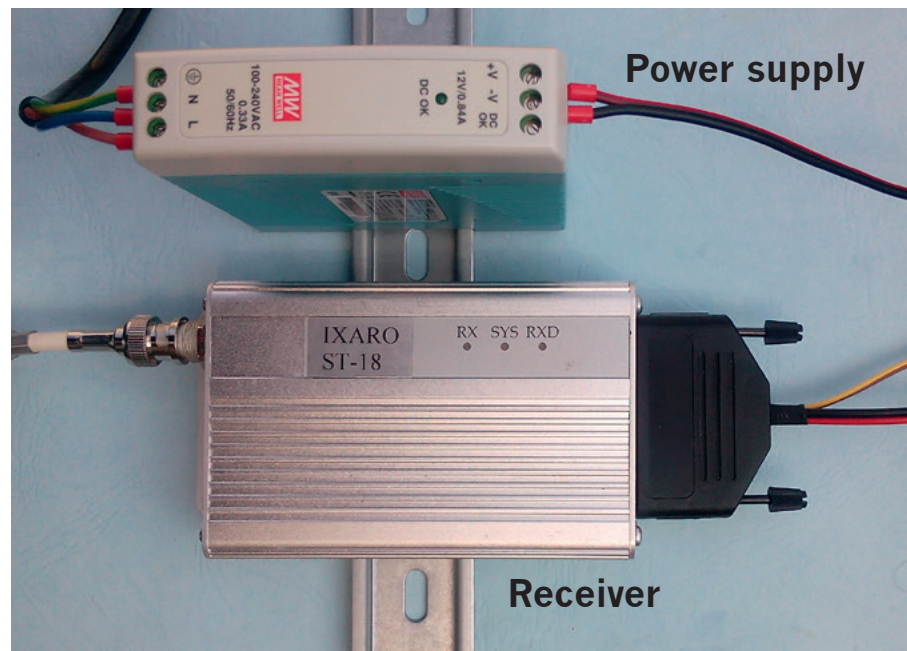


Fig. 2

The receiver ST-18 is connected with a two strand litz wire red (+) , black (-) to the 12V power supply.

The second cable from the connectors hood (yellow/ brown) is from the relay contact which is connected to the barrier control electronics..

2.2 Meaning of LED's for diagnosis

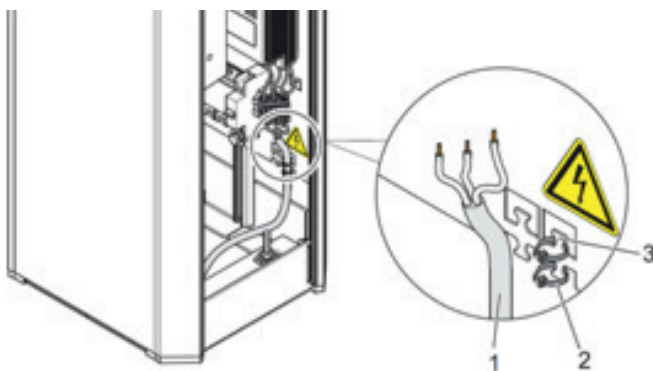
There are three red LEDs at the top lid of the receiver (see Fig. 2). The LED „RX“ lights whenever a signal is received. This may be an extraneous signal that does not contain the keyword „Btn“ to open the barrier. Such messages are excluded by the receivers decoder , the relay output will not be activated. The output will only be activated upon reception of the command „Btn“. The green decoder-LED (Fig. 3) besides the antenna input at the front side of the receiver is lit continuously to indicate operation. It blinks shortly when a barrier opening command has been detected.

The other two LEDs “SYS” and “RXD” at the top lid of the receiver are useful only when the receiver is in programming mode for configuration. The receiver will be delivered preconfigured, programming of the receiver is not necessary.



Fig. 3

The green indicator LED of the command decoder is located besides the antenna input at the receivers front. It is lit continuously. When a command to open the barrier has been detected it goes off and on again.



The excerpt below from the installation manual of the barrier MTHM MicroDrive shows how the receiver power supply may be connected to the depicted mains power terminal and clamped to the existing top hat rail.

- 1 Mains supply
- 2 Cable tie
- 3 Cable tie metal tabs

Power supply

2.3 Mounting of the antenna

The antenna (Fig. 4) is a flat version, thus it is relatively save against breaking off (vandalism). A hole needs to be drilled through the casing of the barrier housing to feed the antenna cable through (see supplement for dimensions). In order to limit the range of reception to approximately 20 meters attenuators are inserted in the antenna cable (Fig. 4,5). The necessary level of attenuation needs to be determined on site because it depends on placement of the antenna and construction of the site.

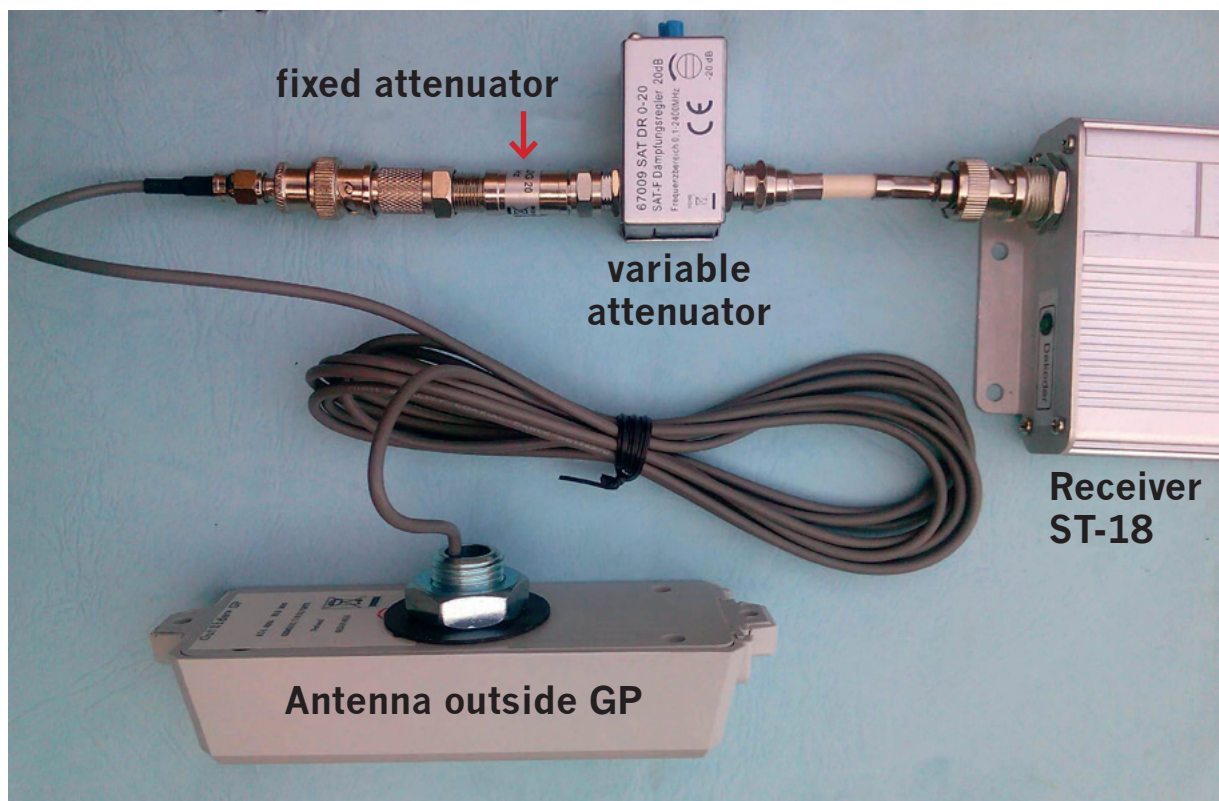


Fig. 4 The complete antenna system

There is a series of attenuators to adjust the range of reception.

The fixed 20 dB attenuator reduces the range to several ten meters around the barrier. The variable attenuator allows to adjust the range accurately.

If a wider range is wanted the fixed attenuator may be removed. The flat antenna is screwed by a central mounting to the outside of the barrier casing.

The antenna is weatherproof, snow may cause dampening of the reception however. Therefore the antenna should be mounted vertical.

For dimension and mounting instruction see the supplement. The chain of attenuators should be secured against the barrier casing with clamps or cable ties.

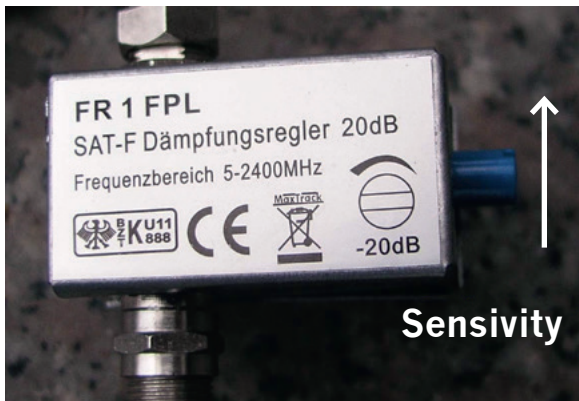


Fig 5

The variable attenuator allows to adjust the range of reception by rotating the axle.

The axle may not be forced over the stop to prevent damage.

2.4 Connection and configuration of the barrier control electronics

The company IXARO can provide recommendations only which are dependent on the manufacturer of the barrier. The following recommendations are intended for the barrier control MTHM micro drive™.

One of the automatic modes like No. 5 seems suitable. The barrier opens upon pressing the button at the pager and closes after a time programmable in the barrier control electronics. Induction loops or photoelectric guards prevent closing of the barrier until the truck has left the area of the barrier.

The receiver's relay output may be connected to one of the inputs „opening low priority”, No.1 or No.2. When an input level of 24 volts is present the barrier opens. One of the relay contacts of the receiver has to be connected with the input, the other contact has to be connected to the 24V output of the barrier control unit (Fig. 6).

Here is an excerpt from the operating manual, chapter 10.7. , of the MTHM MicroDrive barrier concerning mode 5:

Mode 5: Automatic (5) Typical application

This mode is suitable for the automatic operation of a barrier, e.g. with card readers, remote control, coin accepters and induction loops or light barriers. Passage of the barrier is possible in either direction.

Function

The barrier is opened from direction 1 „Safety loop ® Opening loop“ with a pulse at the „Open low priority“ pulse, e.g. with a card reader or coin accepter. The hold-open time that was set is also started. When the vehicle leaves the safety loop, the hold-open time is deleted.

The barrier closes in the following cases:

- If the vehicle drives over both loops in direction 1, the barrier closes as soon as the vehicle leaves the opening loop. The opening loop here acts as an extended safety loop.
- If a vehicle drives onto the safety loop but leaves it again backwards, the barrier closes at once.
- If the vehicle drives over neither of the two loops, i.e. there is no drive through, the barrier closes after the end of the hold-open time.

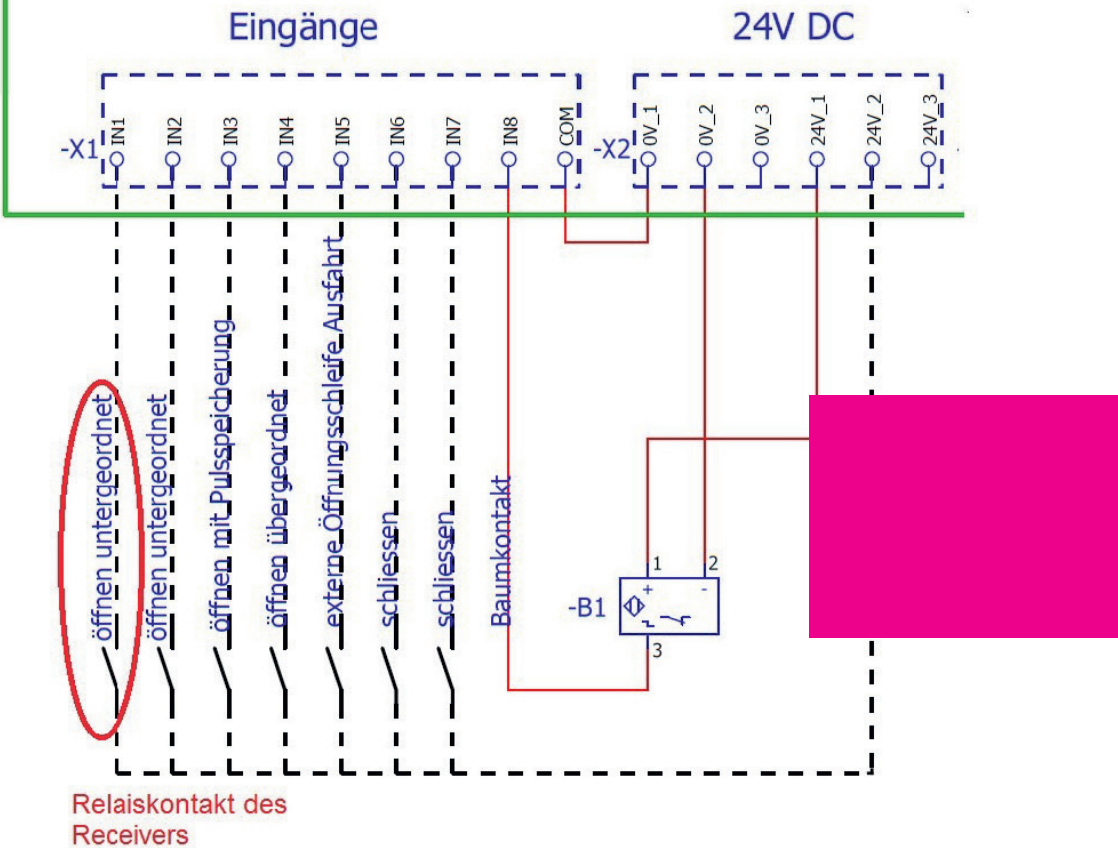
TM:

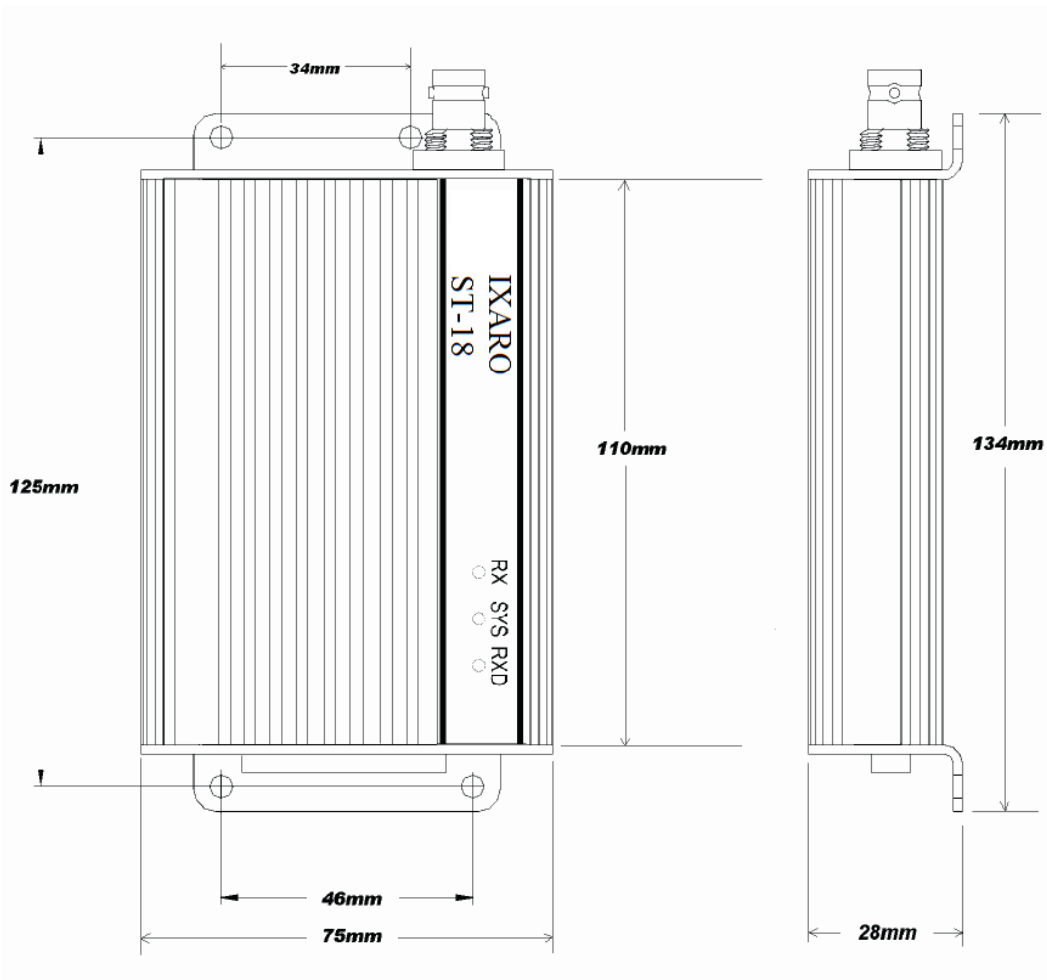
MTHM MicroDrive is trademark of :
MAGNETIC Automation Corporation
3160 Murrell Road
Rockledge, Florida, 32955
USA

Please note: Other brands of barriers will be different to connect. A service technician will be needed to configure the barriers electronics to cooperate with the IXARO system.

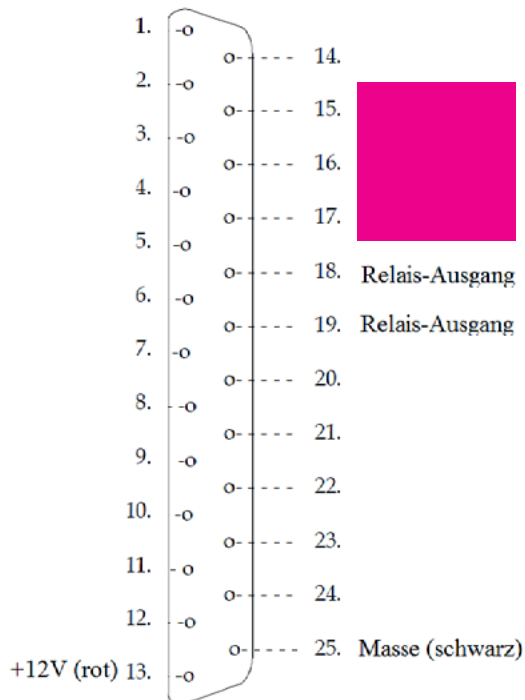


Fig. 6
 Connection of the IXARO Receiver to the barrier control box MTHM Microdrive





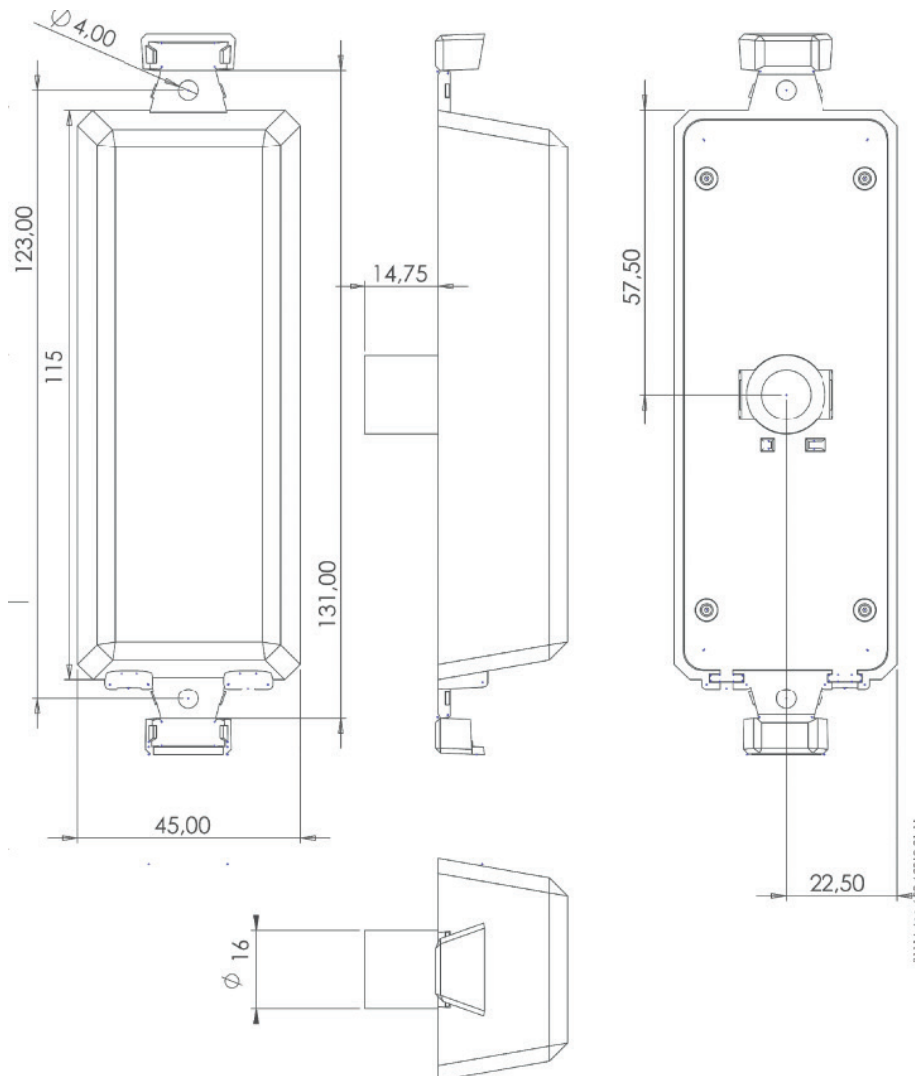
Dimension of the receivers casing



Pinout of the receivers DB25-socket

Only the pins needed for barrier control are indicated. The relay output is wired by a yellow/brown cable. Maximum load of the relay is 200V 15W. Its endurance is 5 Million switching cycles

Only the pins needed for barrier control (Relais-Ausgang = relay output) are indicated. The relay output is wired by a yellow/brown cable. Maximum load of the relay is 200V 15W. Its endurance is 5 Million switching cycles.



Dimensions and mounting holes of the Outside GP antenna

Mounting is accomplished by a central hole of 16mm diameter. Additionally the antenna can be secured against rotation by four 4mm screws at both ends.



IXARO Solutions
Saarburger Ring 32
D-68229 Mannheim
Germany

T.....+49 621.14596
 +49 621.48 17 99 71
F.....+49 621.156 58 22
email....info@ixaro.com

www.ixaro.com